

CRASHS BARRIERES

CRASH BARRIÈRES ALUMINIUM 6005T6

- Finition alu brut (option peinture noire)
- Plancher anti-dérapant
- Equipé d'un nez de marche
- Main courante ø 50 renforcée
- Norme EN-13200-3

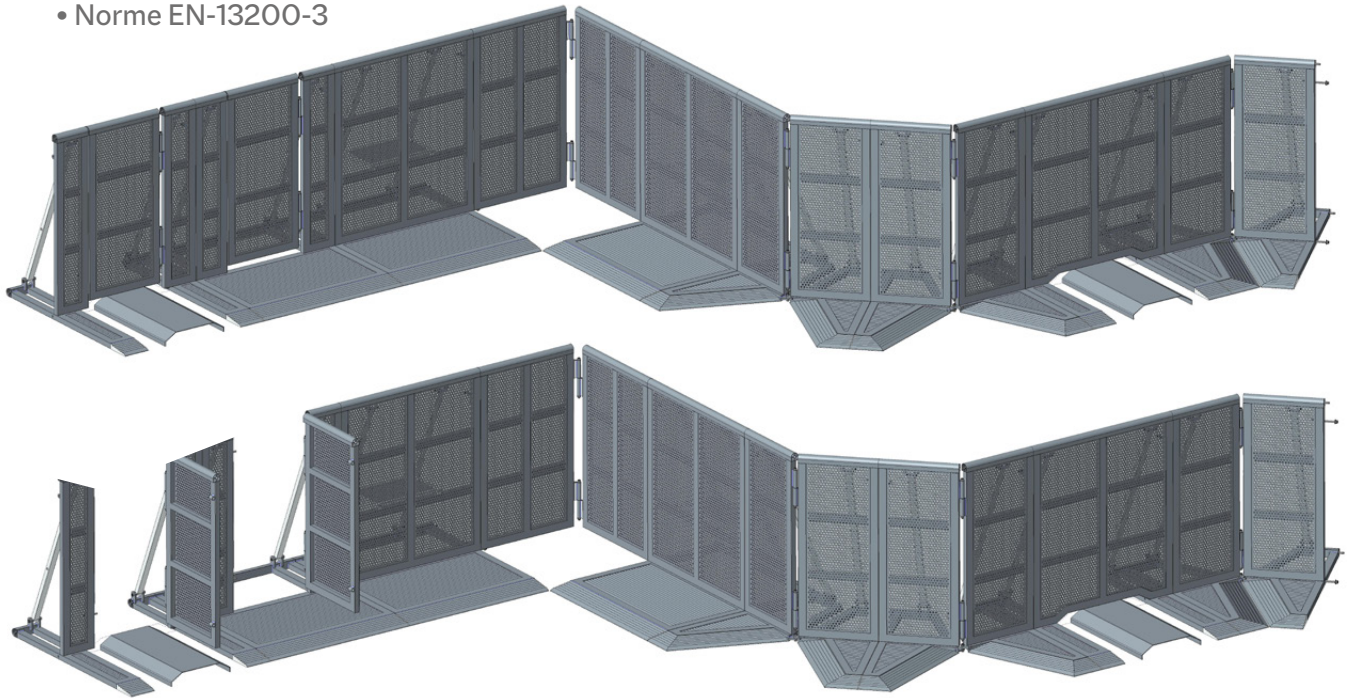

CRASH D

CRASH BARRIÈRE DROIT 1m

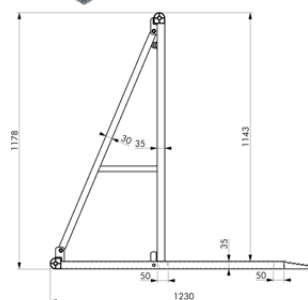
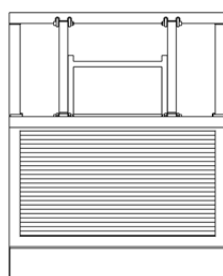
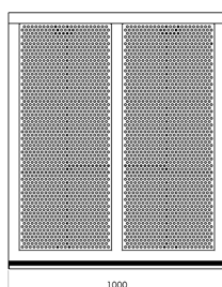

Poids : 39 kg

CRASHS BARRIERES

CRASH 45

CRASH BARRIERE 45° 1 m (DROITE - OUVERTE OU FERMÉE)

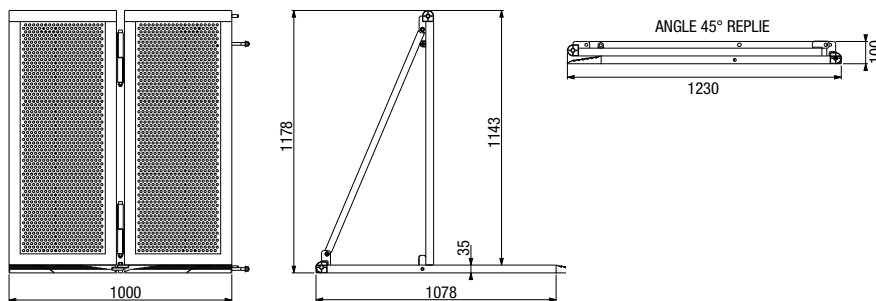

Poids : 33 kg

CRASH 90

CRASH BARRIERE 90° 1 m (DROITE - OUVERTE OU FERMÉE)

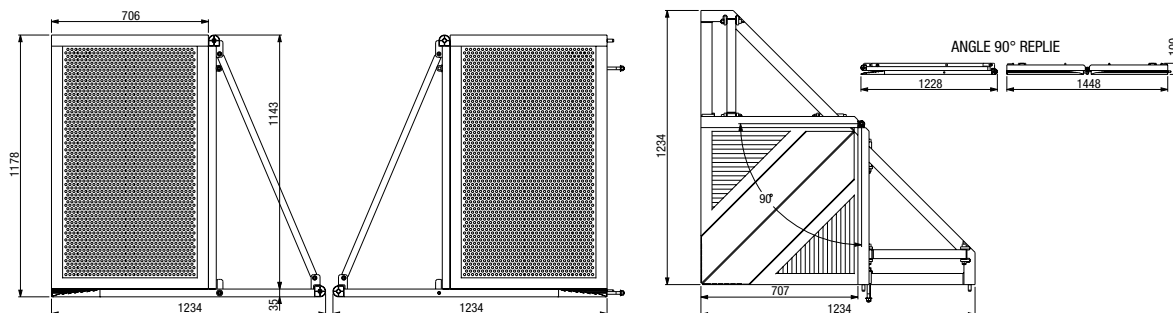
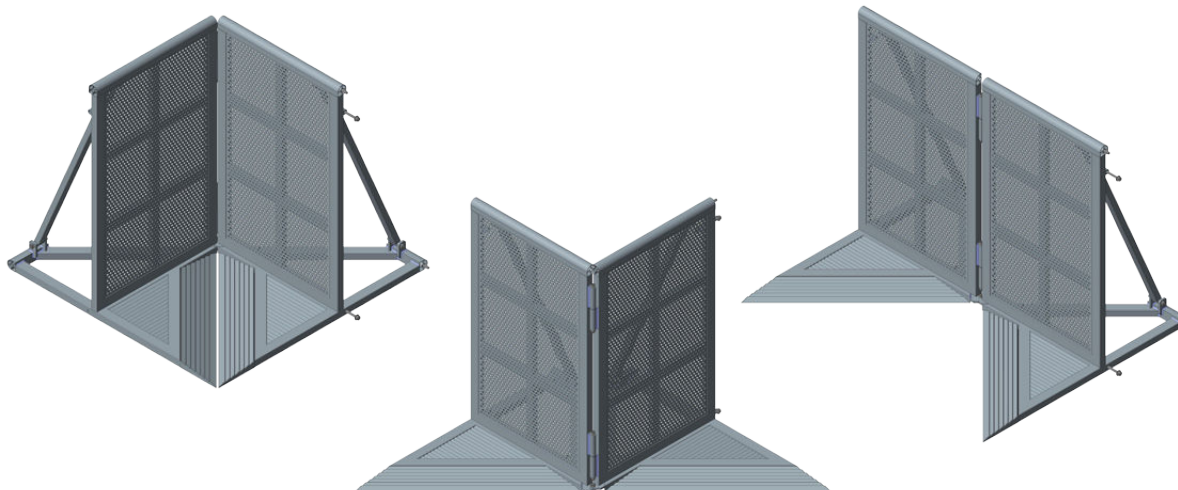

Poids : 25 kg

CRASHS BARRIERES

CRASH VA

CRASH A ANGLE VARIABLE 1m (90° À 270°)

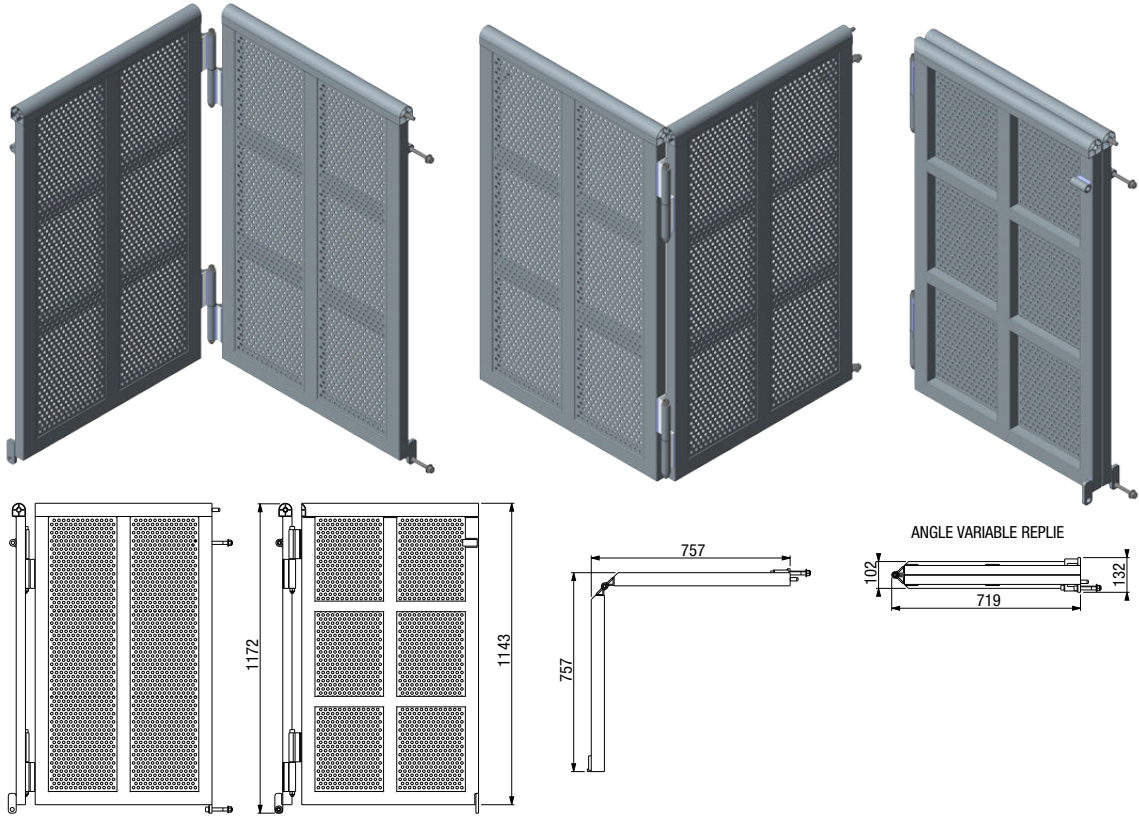

Poids : 37 kg

CRASH BF

CRASH PASSAGE DE CABLE A BARRIERE FIXE

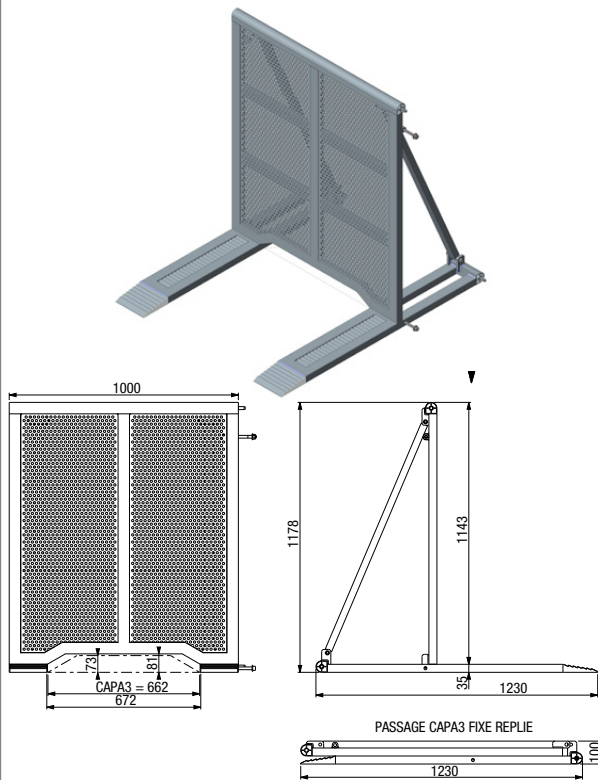

Poids : 37 kg

CRASH BP

CRASH PASSAGE DE CABLE AVEC PORTE

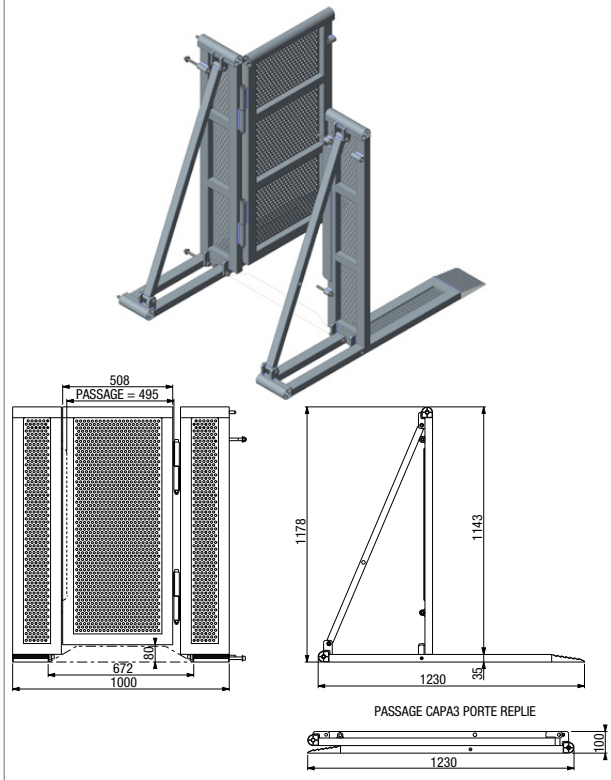

Poids : 39 kg

CRASHS BARRIERES

CHAR CRASH

CHARIOT DE TRANSPORT POUR 8 CRASH BARRIÈRES DROITES (1421 X 1191 X 1213 mm)

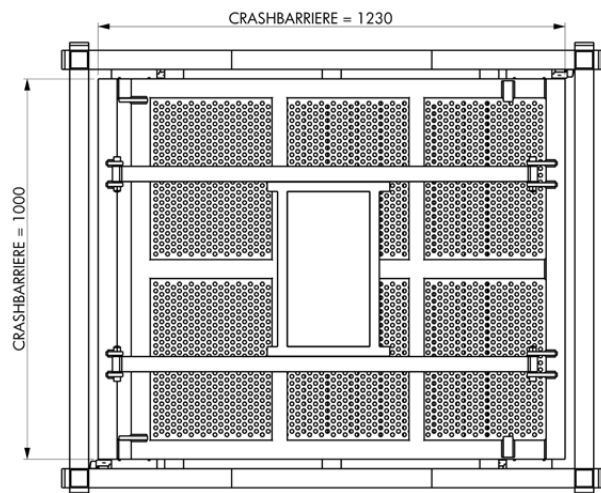
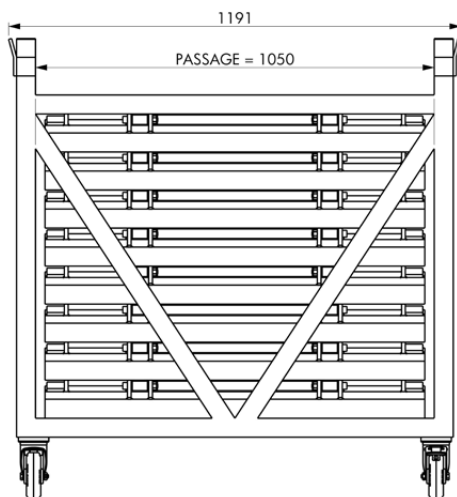
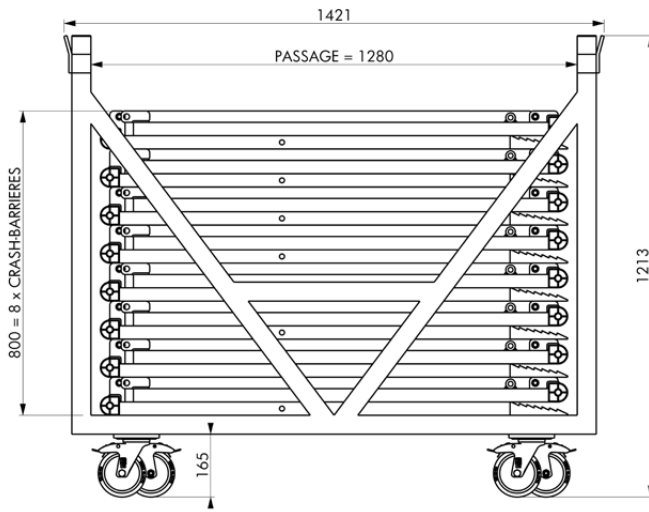
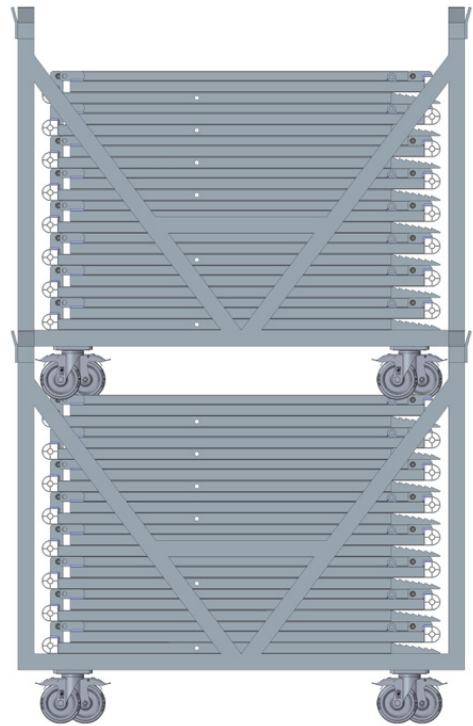
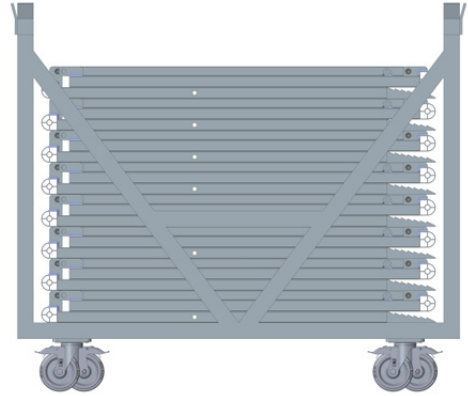
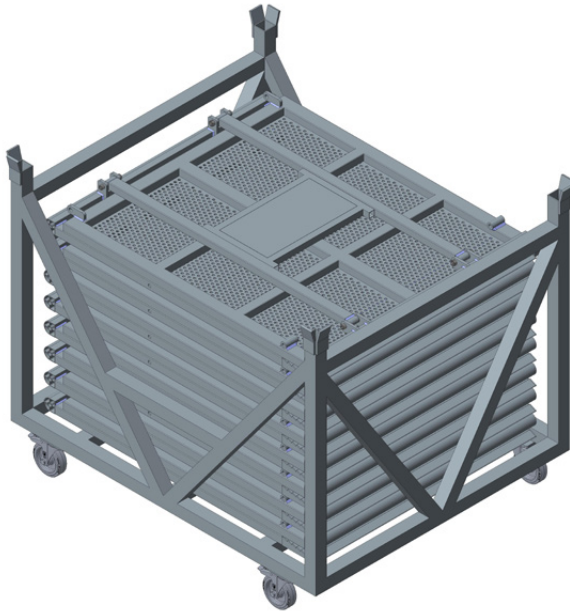

Poids (à charge) : 352 kg